

# Cast Simplex Strainers

## BFH125 - Ductile Iron

### Quick Open Swivel Clamp Cover

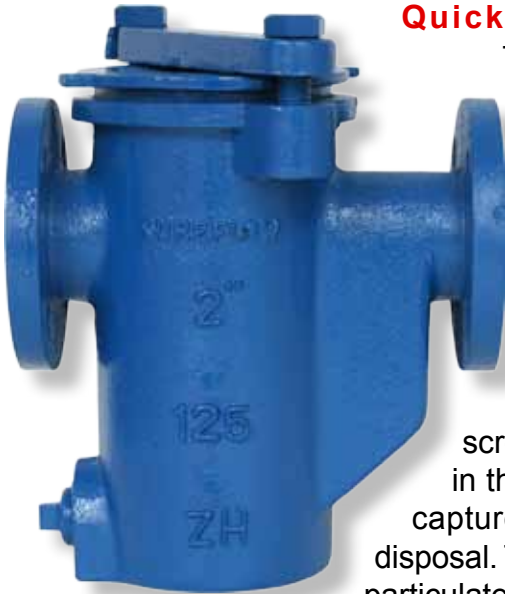

The Sure Flow model BFH125 Basket Strainers are a High Capacity design featuring Class 125 ASME Flanged end connections and top removal of the screen. The screen is

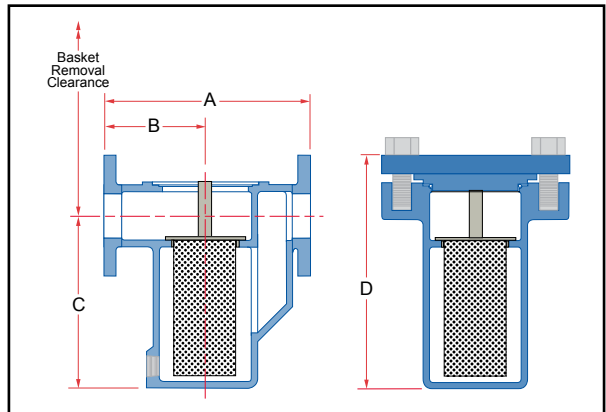

in the form of a basket, with a lifting handle, so that all particulate captured and retained by the screen can be easily removed for disposal. They are intended for applications where larger amounts of solid particulate are expected, and where clean-out will be frequent. Models are standard with a bolted "Swivel Clamp Cover" to allow fast and easy screen removal.

#### Notes:

- Must specify if for steam service
- Manufacturer reserves the right to modify dimensions, materials, or design. Consult factory for certification.

#### Construction

**Ductile Iron** - Body, Cover  
 - ASTM A536 Class 65-45-12  
**BUNA-N** - Cover O-Ring  
 All screens are Stainless Steel

Dimensions (Inches)								
Size		A	B	C	D	Blow Off NPT	Basket Removal Clearance	Shipping Weight (LBS)
Inches	Prefix							
1	0100	7 5/8	3 1/16	5	8 1/4	1/2	6 3/8	55
1 1/2	0150	10 1/4	3 15/16	7	10 5/8	1	8	55
2	0200	10 1/2	4 1/4	7 5/8	11 13/16	1	8 3/4	59
3	0300	13 1/8	4 15/16	10 5/8	15 13/16	1	11 11/16	101
4	0400	16 3/4	6 5/16	10 3/4	17 1/16	1	12	197
6	0600	19 5/8	7 1/2	18 3/8	26	1	19 3/8	362

#### Ordering Information

Example: Include full description

Size	Model	Screen
(Prefix)	Number	Opening
<b>0250</b>	<b>BFH125</b>	<b>045</b>

2 1/2" Basket Strainer, Cast Iron,  
 Class 125 ASME Flanges, 3/64" Perf Screen

#### Operating Pressures and Temperatures

Type	Size	psi @ Temp WOG
BFH125	1" - 6"	150 @ 150 °F

#### Standard Screens

Size	Standard	Opening
1" - 3"	3/64" perf	0.045"
4" - 6"	1/8" perf	0.125"



**Sure Flow**  
 Equipment Inc.

Toll Free: 1-800-263-8251 Toll Free Fax: 1-800-876-1164  
 International: 1-905-335-1350 International Fax: 1-905-332-4993  
 Email: info@sureflowequipment.com www.sureflowequipment.com

