

# Elastic Swing Check Valves

## CXF125IV - Ductile Iron

### ASME Class 125 Flanged End Connections



The **Elastic Swing Check Valve** is suitable for municipal and industrial applications. It is standard with a ductile iron body with ASME Class 125 flanges. The internal body is epoxy coated. The one-piece molded disc has a steel reinforced insert to ensure closure. Plus, while in the open position, it will allow 100% uninterrupted flow. The one-piece disc

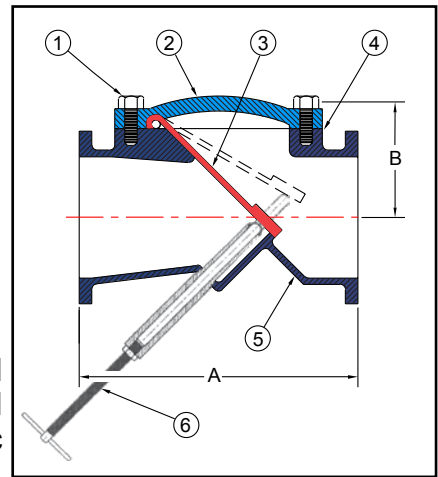

hinge and disc can be repaired without removal of the valve from the line.

*Optional:* A Backflow Rod can be installed and used for draining or pump priming. This option is a safe and effective way to manually activate the valve.

#### Notes:

Manufacturer reserves the right to modify dimensions, materials, or design. Consult factory for certification.

Construction		
Item	Description	Material
1	Cover Bolts	Alloy Steel SAE Grade 5
2	Cover	A536 60-45-12 Ductile Iron
3	Disc	Buna-N with Steel & Fabric Reinforcement
4	Gasket	Lexide NK-511 (non-asbestos)
5	Cast Body	A536 60-45-12 Ductile Iron
6	Backflow Rod (Optional)	A582, B505 Brass

Dimensions (Inches)						
Size		A	B	Drain Size	Cv	Shipping Weight (LBS)
Inches	Prefix					
2	0200	8	3 3/8	3/4	95	30
2 1/2	0250	8 1/2	3 3/8	3/4	155	38
3	0300	9 1/2	3 7/8	3/4	225	46
4	0400	11 1/2	4 5/8	1	440	70
5	0500	13 3/4	5 1/8	1	722	105
6	0600	15	5 7/8	1 1/4	1,040	115
8	0800	19 1/2	7 5/8	1 1/2	1,900	250
10	1000	24 1/2	9 7/8	2 1/2	3,050	525
12	1200	27 1/2	11 1/2	2 1/2	4,600	710
14	1400	31	13 1/2	2 1/2	6,600	860
16	1600	31 15/16	15 1/4	2 1/2	8,700	1,090
18	1800	35 15/16	17 1/4	3	11,200	1,450
20	2000	39 15/16	19 1/4	3	14,200	1,720
24	2400	47 15/16	22 3/4	3	21,000	2,600

### Ordering Information

Example: Include full description

Size	Model
(Prefix)	Number
<b>0400</b>	<b>CXF125IV</b>

4" Flanged Elastic Swing Check Valve, Ductile Iron, Buna-N Disc with Steel and Fabric Reinforcement.

Operating Pressures and Temperatures		
Type	Size	psi @ Temp WOG
CXF125IV	2" - 12"	200 @ 150 °F
	14" - 24"	150 @ 150 °F



**Sureflow**  
Equipment Inc.

Toll Free: 1-800-263-8251 Toll Free Fax: 1-800-876-1164  
International: 1-905-335-1350 International Fax: 1-905-332-4993  
Email: info@sureflowequipment.com www.sureflowequipment.com

