

Elastic Swing Foot Valves

FVCEXF125 - Ductile Iron

ASME Class 125 Flanged End Connections



The **Elastic Swing Foot Valve** is standard with a ductile iron body, ASME Class 125 flanges and is suitable for municipal and industrial applications. The internal body is epoxy coated. Special coatings are available upon request. The one-piece molded disc has a steel reinforced insert to ensure closure, but while in the open position will allow 100% uninterrupted flow. The one-piece disc hinge and flapper can be repaired without removal of the valve from the line. The Elastic Swing Foot Valve is designed for continuous flow applications and is not recommended for reciprocating pumps. The Elastic Swing Foot Valve can be installed in a vertical or horizontal pipeline.

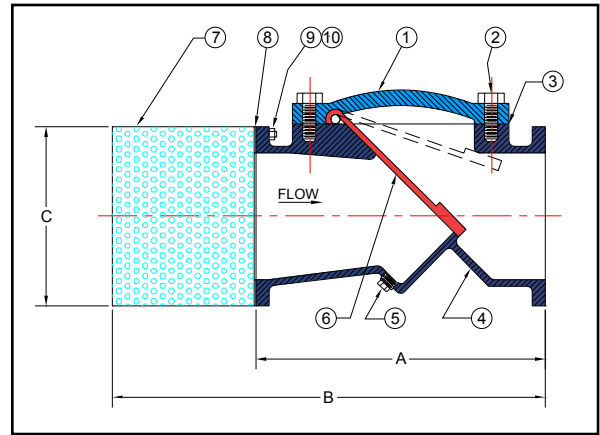

Notes:

- Valve comes standard with 1/8" perf. Stainless Steel Screen. Options are available.
- Horizontal Flow:** Valve must be installed with cover on top to ensure proper operation.

Manufacturer reserves the right to modify dimensions, materials, or design. Consult factory for certification.

		Construction									
Item		1	2	3	4	5	6	7	8	9	10
Description		Cover	Cover Bolts	Gasket	Cast Body	Drain	Disc	Screen Assembly	Plate Flange	Studs	Nuts

Size		Dimensions (Inches)			Drain Size	Cv	Shipping Weight (LBS)
Inches	Prefix	A	B	C			
2	0200	8	10 1/2	6 1/4	3/4	76	36
2 1/2	0250	8 1/2	11	7 1/4	3/4	124	46
3	0300	9 1/2	12	7 3/4	3/4	180	55
4	0400	11 1/2	14	9 1/4	1	352	84
5	0500	13 3/4	16 3/4	10 1/4	1	578	120
6	0600	15	19 1/2	11 1/4	1 1/4	832	138
8	0800	19 1/2	25	13 3/4	1 1/2	1,520	300
10	1000	24 1/2	31	16 1/4	2 1/2	2,440	630
12	1200	27 1/2	35	19 1/4	2 1/2	3,680	852
14	1400	31	39 1/2	21 1/4	2 1/2	5,280	1,032
16	1600	31 15/16	41 7/16	23 3/4	2 1/2	6,960	1,308
18	1800	35 15/16	47 7/16	25 1/4	3	8,960	1,740
20	2000	39 15/16	55 7/16	27 3/4	3	11,360	1,890
24	2400	47 15/16	65 7/16	32 1/4	3	16,800	3,120

Ordering Information

Example: Include full description

Size Model
(Prefix) Number
0400 FVCEXF125

4" Flanged Elastic Swing Foot Valve, Ductile Iron,
Buna-N Disc with Steel and Fabric Reinforcement.

Operating Pressures and Temperatures		
Type	Size	psi @ Temp WOG
FVCEXF125	2" - 12"	200 @ 150 °F
	14" - 24"	150 @ 150 °F



Sure Flow
Equipment Inc.

Toll Free: 1-800-263-8251 Toll Free Fax: 1-800-876-1164
International: 1-905-335-1350 International Fax: 1-905-332-4993
Email: info@sureflowequipment.com www.sureflowequipment.com

