

Fabricated Y Strainers

FW600 - Carbon Steel
FW600SS - Stainless Steel

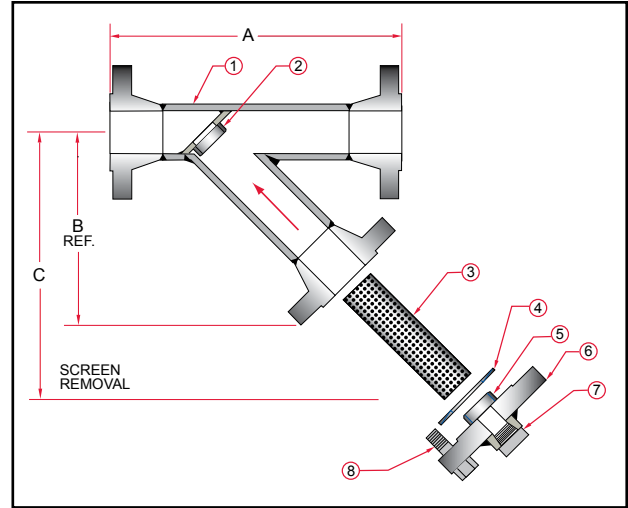

Notes:

- Higher ASME pressure ratings available
- Larger sizes available

Manufacturer reserves the right to modify dimensions, materials, or design. Consult factory for certification.

Construction								
Item	1	2	3	4	5	6	7	8
Description	Body Assembly	Screen Guide	Screen	Gasket	Screen Guide	Blind Flange	Drain Assembly	Bolting

Dimensions (Inches)				
Size		A	B	C
Inches	Prefix			
2	0200	16	14	19
2 1/2	0250	17	15	21
3	0300	19	17	24
4	0400	22	20	28
5	0500	26	24	34
6	0600	28	26	37
8	0800	34	32	45
10	1000	40	34	48
12	1200	44	36	50
14	1400	50	38	53
16	1600	55	41	58
18	1800	60	45	63
20	2000	65	50	70
24	2400	75	55	77

Ordering Information

Example: Include full description

Size (Prefix)	Model Number	Screen Opening
0800	FW600	125

8" Y Strainer, Carbon Steel, Class 600 ASME Flanges, 1/8" Perf Screen.

Operating Pressures and Temperatures			
Type	Size	psi @ Temp Steam	psi @ Temp WOG
FW600	2" - 24"	600 @ 489 °F	1480 @ 100 °F
FW600SS	2" - 24"	600 @ 489 °F	1440 @ 100 °F



Sure flow
Equipment Inc.

Toll Free: 1-800-263-8251 Toll Free Fax: 1-800-876-1164
 International: 1-905-335-1350 International Fax: 1-905-332-4993
 Email: info@sureflowequipment.com www.sureflowequipment.com

