

Fabricated Y Strainers

FWT150 / FWT300 - Carbon Steel
FWT150SS / FWT300SS - Stainless Steel

With Standard Butt Welded Fittings



The Sure Flow Fabricated "FWT" Y strainer differs from the "FW" Y strainer by incorporating standard butt welded components into its construction. Fabricated in Carbon or Stainless Steel, pipe sizes 2" through 24" and in Class 150 and Class 300 ASME flanges, the standard strainer is suited for many applications.

Sure Flow also has the capability to

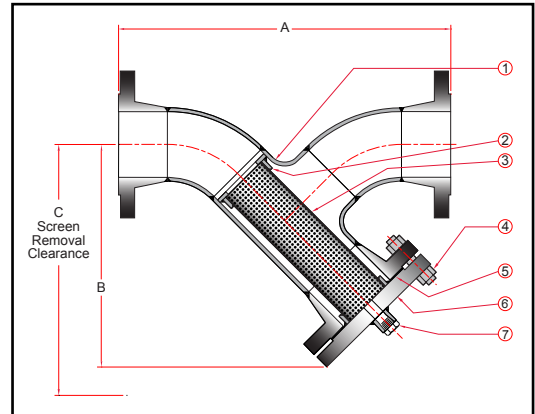

supply larger pipe sizes and/or higher ASME pressure ratings where needed. Screen sizes can be tailored to hold sufficient solids for the required time between clean-outs. Flange sizes can be chosen to fit existing piping, or to achieve the required clean pressure drop. Hinge covers are also available for quick opening. Alternate materials of construction are available. Please contact factory for details.

Notes:

- Higher ASME pressure ratings available
- Larger sizes available

Manufacturer reserves the right to modify dimensions, materials, or design. Consult factory for certification.

		Construction						
Item		1	2	3	4	5	6	7
Description		Body Assembly	Screen Guide	Screen	Bolting	Gasket	Blind Flange	Drain Assembly

Dimensions (Inches)							
Size		A		B		C	
Inches	Prefix	150	300	150	300	150	300
2	0200	13 1/4	13 3/4	9	9 7/16	12	12 1/4
2 1/2	0250	15 11/16	16 1/4	10 5/8	10 15/16	14 1/8	14 1/4
3	0300	17 1/8	17 7/8	11 9/16	12 3/16	15 5/8	16
4	0400	20 3/8	21 1/8	13 5/8	14 1/2	18 1/2	19
5	0500	24 9/16	25 5/16	15 7/8	16 13/16	22 1/2	22 1/2
6	0600	27 3/4	28 1/2	17 3/4	18 15/16	25 1/2	25 1/2
8	0800	35	35 3/4	22	23 1/16	31	31 1/2
10	1000	41 3/8	42 1/2	25 7/8	27 5/16	36 3/4	37 1/8
12	1200	48 3/4	49 15/16	30 5/16	31 13/16	42 7/8	43 3/4
14	1400	55 7/16	56 11/16	33 11/16	35 7/16	47 3/8	48 3/4
16	1600	61 3/16	62 5/8	36 15/16	38 7/8	52 7/8	53 7/8
18	1800	68 1/2	70	40 15/16	43 1/8	59 1/2	60
20	2000	78 1/4	76 5/8	45 1/16	47 3/16	65 1/2	66 1/4
24	2400	87 1/4	88 1/2	51 5/8	54 1/16	73 1/4	75 1/8

Ordering Information

Example: Include full description

Size Model Screen
 (Prefix) Number Opening
0400 **FWT150** **125**

4" Y Strainer, Carbon Steel, Class 150 ASME Flanges, 1/8" Perf Screen.

Operating Pressures and Temperatures

Type	Size	psi @ Temp Steam	psi @ Temp WOG
FWT150	2" - 24"	150 @ 366 °F	285 @ 100 °F
FWT150SS	2" - 24"	150 @ 366 °F	275 @ 100 °F
FWT300	2" - 24"	300 @ 422 °F	740 @ 100 °F
FWT300SS	2" - 24"	300 @ 422 °F	720 @ 100 °F



Sure flow
 Equipment Inc.

Toll Free: 1-800-263-8251 Toll Free Fax: 1-800-876-1164
 International: 1-905-335-1350 International Fax: 1-905-332-4993
 Email: info@sureflowequipment.com www.sureflowequipment.com

