

Fabricated Basket Strainers

BWH150 / BWH300 - Carbon Steel
BWH150SS / BWH300SS - Stainless Steel

With Quick Opening Hinged Cover

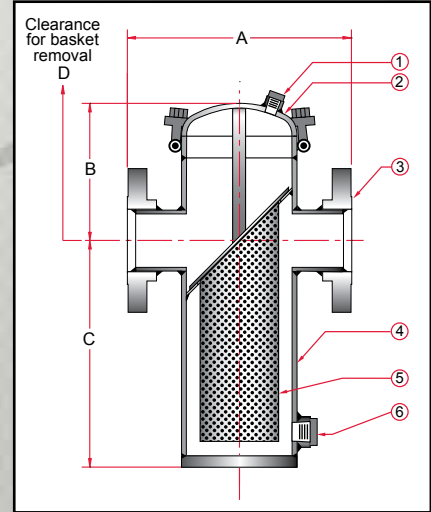

Notes:

- Higher ASME pressure ratings available
- Larger sizes available

Manufacturer reserves the right to modify dimensions, materials, or design. Consult factory for certification.

Construction						
Item	1	2	3	4	5	6
Description	Vent Assembly	Quick Open Cover	Inlet/Outlet Flange	Body Assembly	Basket	Drain Assembly

Dimensions (Inches)						
Size			A	B	C	D
Inches	Prefix	Body	150 and 300	150 and 300	150 and 300	150 and 300
2	0200	6	14	8 5/8	12 1/4	26
2 1/2	0250	6	15	8 5/8	12 3/4	26
3	0300	6	15	8 5/8	12 3/4	26
4	0400	8	16	9 1/2	14 5/16	28
5	0500	10	16	11 1/4	15 5/8	32
6	0600	10	20	11 1/4	17 3/8	34
8	0800	12	22	13	21 5/8	42
10	1000	16	32	15 3/4	25 7/8	50
12	1200	18	35	17 3/4	28	56
14	1400	20	37	19 3/4	34 1/8	65
16	1600	24	42	23 1/4	36	67
18	1800	24	42	23 1/4	40 1/4	76
20	2000	30	43	27 3/4	45 1/8	82
24	2400	36	52	27 3/4	61 1/2	102

Ordering Information

Example: Include full description

Size Model Screen
 (Prefix) Number Opening
1200 BWH300SS 125

12" Basket Strainer, Stainless Steel, Class 300 ASME Flanges, 1/8" Perf Screen, Hinged Cover

Operating Pressures and Temperatures			
Type	Size	psi @ Temp Steam	psi @ Temp WOG
BWH150	2" - 24"	150 @ 366 °F	285 @ 100 °F
BWH150SS	2" - 24"	150 @ 366 °F	275 @ 100 °F
BWH300	2" - 24"	300 @ 422 °F	740 @ 100 °F
BWH300SS	2" - 24"	300 @ 422 °F	720 @ 100 °F



Sure flow
 Equipment Inc.

Toll Free: 1-800-263-8251 Toll Free Fax: 1-800-876-1164
 International: 1-905-335-1350 International Fax: 1-905-332-4993
 Email: info@sureflowequipment.com www.sureflowequipment.com