

Specifications / Dimensions / Weights

Model SFA30 & SFA31 24" - 36" Carbon Steel

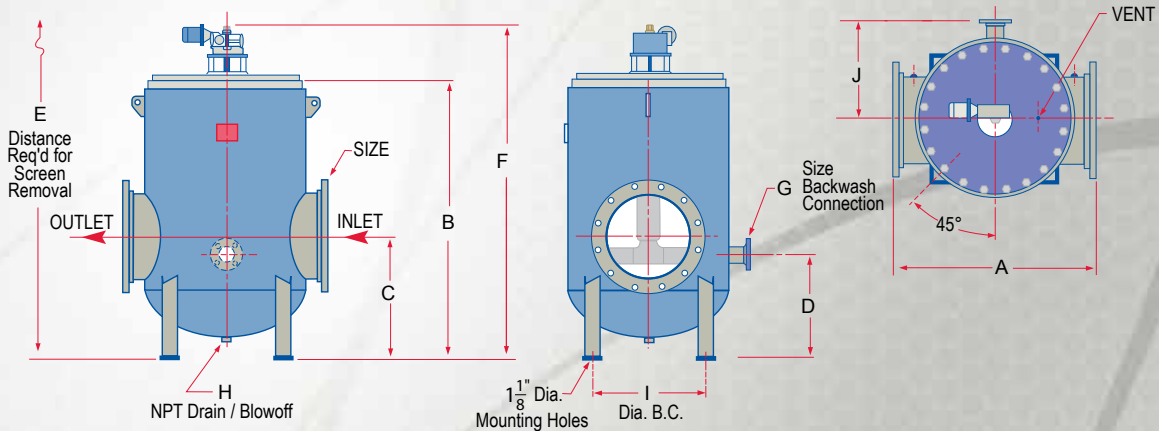

Model No.	Size (in)	A (in)	B (in)	C (in)	D (in)	E (in)	F (in)	G (in)	H (in)	I (in)	J (in)	Approx. Wts. (Lbs.)			Motor H.P.
												Dry	Wet	Cov.	
2400-SFA30/31	24-150	56	77	33	28	122	98	4-150	2 NPT	44	28	4,500	8,475	610	1/3
3000-SFA30/31	30-150	66	94	39	34 1/4	150	115	4-150	2 NPT	54	33	6,525	13,625	1,275	1/3
3600-SFA30/31	36-150	86	120	48	40 1/2	210	132	6-150	2 NPT	72	43	12,050	26,975	1,650	1/2

Larger sizes available upon request. Dimensions subject to change without notice. Contact factory for certified drawings.

Typical Backwash Flow Requirement

Strainer Size	Model SFA10 / SFA20 (1" - 8")				Model SFA30 (10" - 36")						
	1", 1-1/2" 2" or 3"	4"	6"	8"	10/12"	14/16"	18/20"	24"	30"	36"	
Backwash Line Size	1"	1"	1-1/2"	1-1/2"	2"	3"	3"	4"	4"	6"	
Backwash Flow in GPM	8-12	15-20	30-40	60-75	110-150	170-210	250-310	400-490	550-700	750-900	

Flow Rate Vs. Pressure Drop (Clean Screen)

Model SFA30 & SFA31

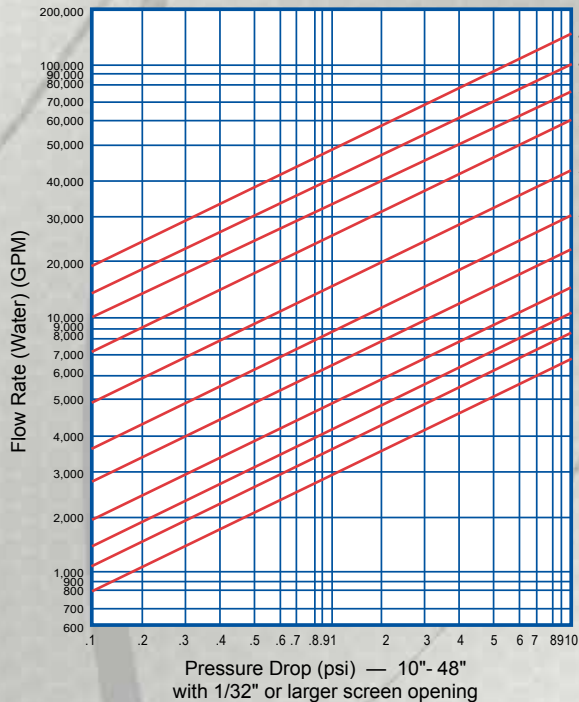

Model SFA20

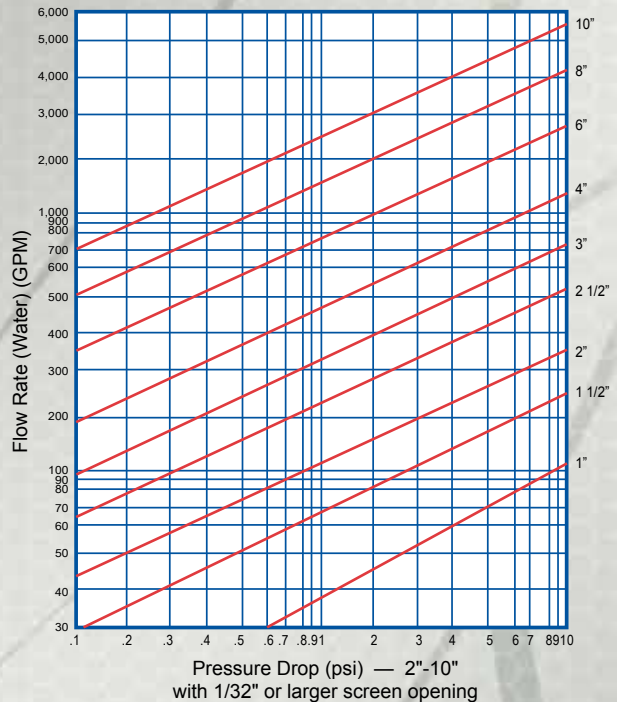

NOTE: These charts are for theoretical calculations ONLY. Please contact our office with your exact specifications and you will be provided with factory calculations.