

Cast Y Strainers

YF125 - Cast Iron

Class 125 Flanged End Connections



Sure Flow Cast Iron Flanged Strainers feature a machined seat which ensures a perfect fit for the removable, stainless steel screen. All sizes come complete with flanged blow-off cover, gasket & plug. May be installed in vertical or horizontal pipelines with blow-off connection at the lower end of the screen.

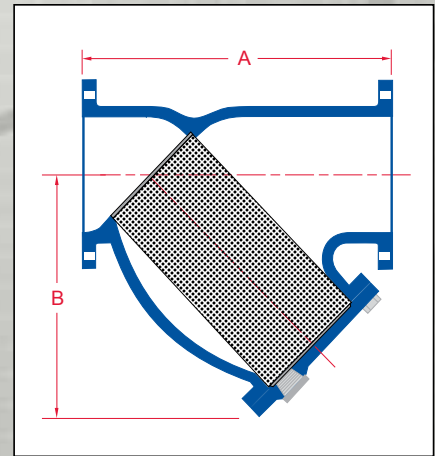

Notes:

- Must specify if for steam service

Manufacturer reserves the right to modify dimensions, materials, or design. Consult factory for certification.

Construction

Cast Iron - Body, Cover and Plug

- High Tensile ASTM A126 Class B

All screens are Stainless Steel

Dimensions (Inches)					
Size		A	B	Blow-Off NPT	Shipping Weight (LBS)
Inches	Prefix				
2	0200	7 7/8	5 1/4	1/2	21
2 1/2	0250	10	6 1/2	1	32
3	0300	10 1/8	7	1	39
4	0400	12 1/8	8 1/4	1 1/2	69
5	0500	15 5/8	11 1/4	2	110
6	0600	18 1/2	13 1/2	2	153
8	0800	21 5/8	15 1/2	2	284
10	1000	25 3/4	18 1/2	2	426
12	1200	29 7/8	21 3/4	2	667
14	1400	33 1/4	25	2	903
16	1600	38 3/8	26 1/2	2	1254
18	1800	43 1/8	31	2	1642
20	2000	49 1/2	36 1/4	2	2615

Ordering Information

Example: Include full description

Size	Model	Screen
(Prefix)	Number	Opening
0400	YF125	125

4" Flanged, Y Strainer, Cast Iron, Class 125
ASME Flanges, 1/8" Perf Screen

Operating Pressures and Temperatures

Type	Size	psi @ Temp Steam*	psi @ Temp WOG
YF125	2" - 12"	125 @ 344 °F	200 @ 150 °F
YF125	14" - 20"	125 @ 344 °F	150 @ 150 °F

Standard Screens

Size	Standard	Opening
2" - 3"	3/64" perf	0.045"
4" - 20"	1/8" perf	0.125"



Sure Flow
Equipment Inc.

Toll Free: 1-800-263-8251 Toll Free Fax: 1-800-876-1164
International: 1-905-335-1350 International Fax: 1-905-332-4993
Email: info@sureflowequipment.com www.sureflowequipment.com