

Duplex Strainers

Top View: Threaded Model

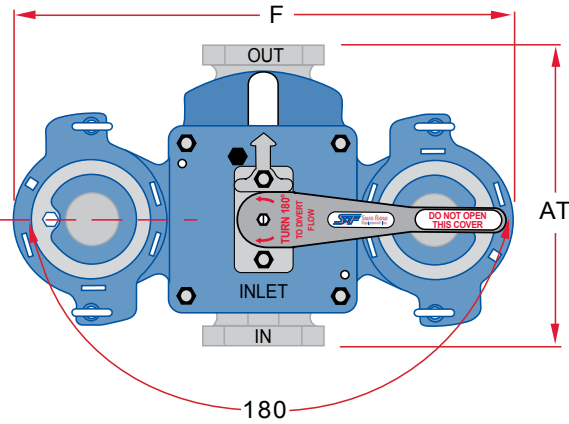

Top View: Flanged Model

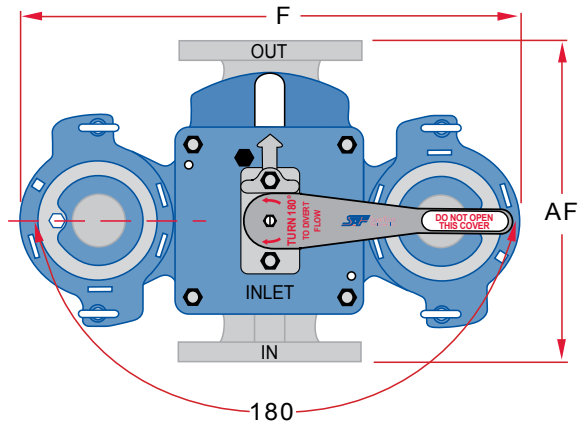

Front View: Flanged and Threaded Models

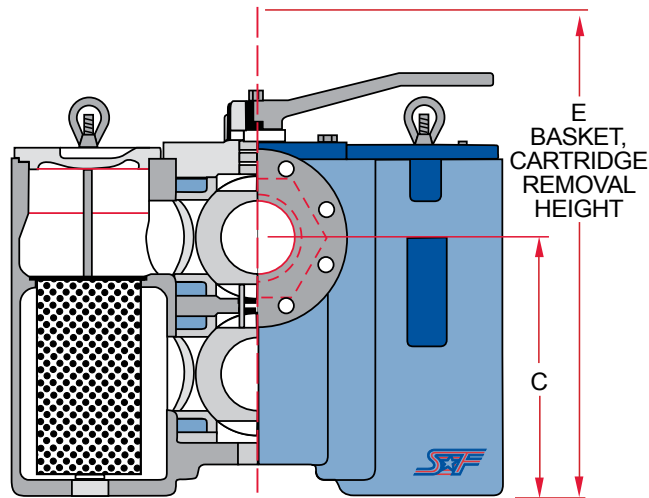

Dimensional Data (Inches)

Size		AF	AT	C	E	F	Shipping Weight (lbs.)					
							Cast Iron		Bronze		Carbon & SS	
Inches	Prefix						Flanged	Threaded	Flanged	Threaded	Flanged	Threaded
3/4	0075	-	5 1/2	5	13 3/8	10 1/2	-	45	-	56	-	52
1	0100	6 7/8	5 1/2	5	13 3/8	10 1/2	52	45	65	56	65	52
1 1/4	0125	6 7/8	7 1/2	6 13/16	17	13 1/4	-	90	-	115	-	110
1 1/2	0150	9 3/8	7 1/2	6 13/16	17	13 1/4	109	90	130	115	120	110
2	0200	10 5/8	10	8 3/8	21 3/4	17 3/8	190	180	230	220	210	195
2 1/2	0250	10 3/4	10	8 3/8	21 3/4	17 3/8	210	180	260	220	235	195
3	0300	13 1/2	-	8 7/8	26 1/2	22 3/4	340	-	380	-	460	-
4	0400	16	-	13 1/4	33	24 3/4	430	-	535	-	460	-

1/4" NPT cover vent taps are standard on all strainers.

1/4" NPT basket well drain connectors are standard on all strainer sizes.

Dimensions and weights are for reference only. Please contact Sure Flow Equipment Inc. for certified drawings.



Sure flow
Equipment Inc.

Toll Free: 1-800-263-8251 Toll Free Fax: 1-800-876-1164
International: 1-905-335-1350 International Fax: 1-905-332-4993
Email: info@sureflowequipment.com www.sureflowequipment.com

