

FRP Duplex Strainers

FRP (Fiberglass Reinforced Plastic) Duplex Strainers

Sure Flow FRP Duplex Basket Strainers are ideal for applications in water environments, water parks, commercial swimming pools and aquariums. They are also an ideal choice for industrial and chemical resistant applications.

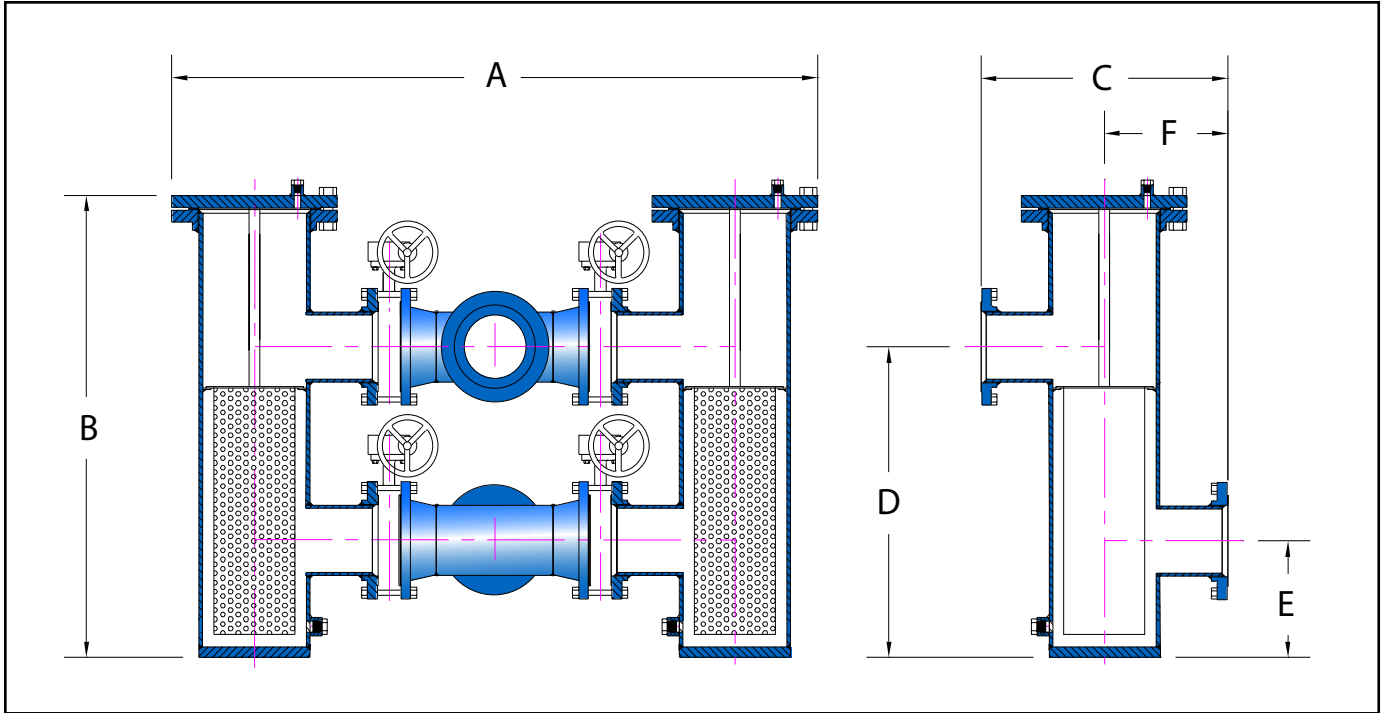

Notes:

- Larger sizes available

Manufacturer reserves the right to modify dimensions, materials, or design. Consult factory for certification.

Dimensions (Inch)						
Size	A	B	C	D	E	F
2" & 3"	36	20	10 7/8	26	6	6
4"	38	26	14 1/2	30	10	7 1/4
5"	51 1/2	38	25 1/4	30	10	13
6"	51 1/2	38	25 1/4	30	10	13
8"	60	48	26 1/4	37 1/2	12	14
10"	70 3/4	56	30	42	12	15
12"	75	64	32	48	12	16
14"	89	66	36	50	14	18
16"	107 1/2	68	40	50	14	20



**Sure Flow
Equipment Inc.**

Toll Free: 1-800-263-8251 Toll Free Fax: 1-800-876-1164
International: 1-905-335-1350 International Fax: 1-905-332-4993
Email: info@sureflowequipment.com www.sureflowequipment.com

