

DIMENSIONS (INCH)					
SIZE	A	B	C	D THREAD	E B.C.
2	2 3/8	6 1/2	2 3/8	5/8-11UNC	5
3	2 7/8	8 1/4	3 3/4	3/4-10UNC	6 5/8
4	2 7/8	10	4 1/2	3/4-10UNC	7 7/8
6	3 7/8	12 1/2	6 5/8	3/4-10UNC	10 5/8
8	5	15	8 5/8	7/8-9UNC	13
10	5 3/4	17 1/2	10 3/4	1-8UNC	15 1/4

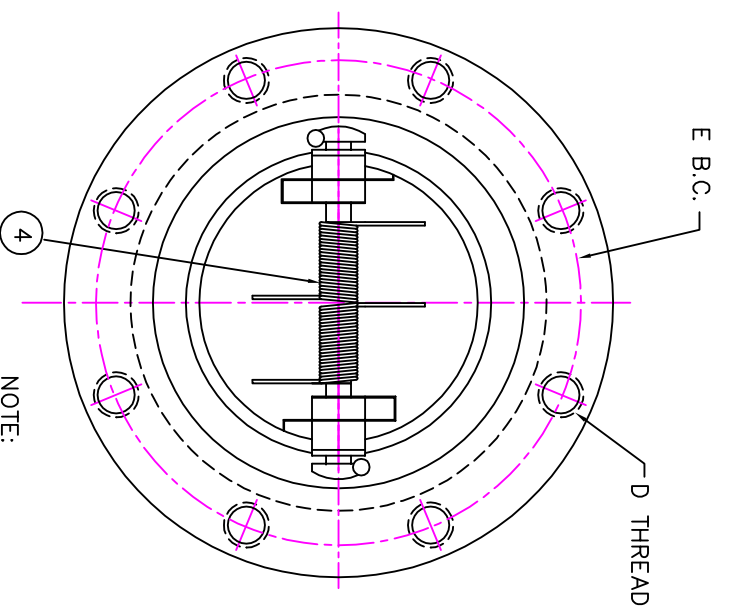
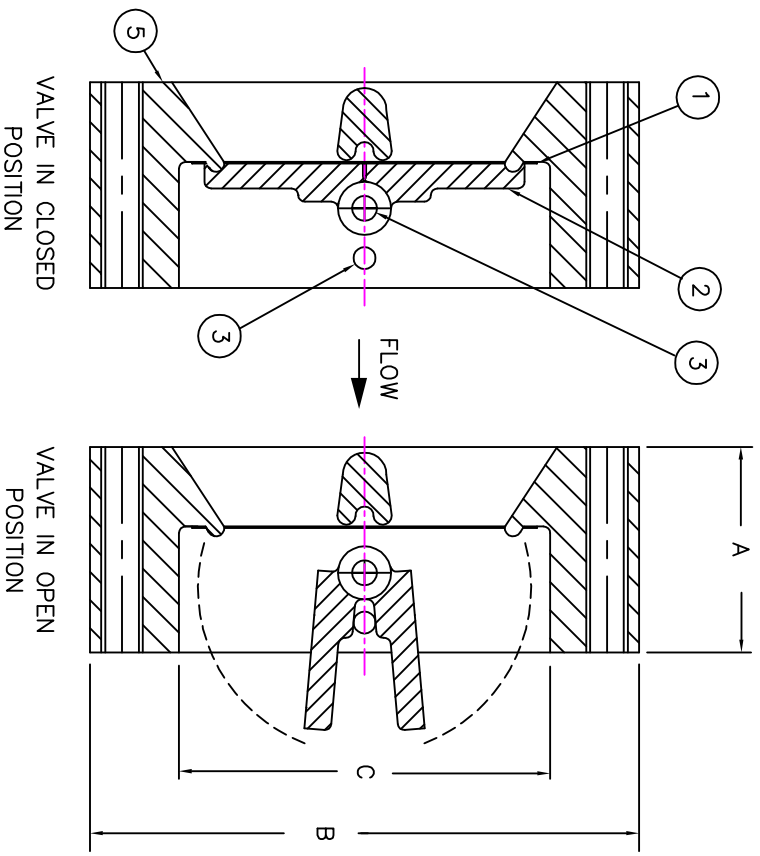

PARTS LIST			
ITEM	DESCRIPTION	SPECIFICATIONS	QTY
1	SEAT/SEAL	VITON/316 STAINLESS STEEL	1
2	DISC	SA351 CF8M	2
3	SHAFT	316 STAINLESS STEEL	2
4	TORSION SPRING	INCONEL	2
5	CAST BODY	SA351 CF8M	1

NOTE:
 FLANGES CORRESPOND TO THE
 REQUIREMENTS OF ASME STANDARD B16.5
 FOR APPROVAL OR QUOTATION PURPOSE ONLY

SURE FLOW EQUIPMENT INC.
 This drawing is the property of Sure Flow Equipment Inc. It shall not be copied or duplicated in any manner and shall not be submitted to outside parties for examination without the written consent of Sure Flow Equipment Inc. It shall be used for reference to work under contract, or for proposals submitted by Sure Flow Equipment Inc. only.

Sure Flow Equipment Inc.
 BURLINGTON, ONTARIO, CANADA

Model **2"-10" FE300SSL CHECK VALVES**

Drawn **C. MACCARETTA** Approved _____
 Date **JULY 3/07** Drawing Number **Q04775** Scale **NTS**