

DIMENSIONS (INCH)					
SIZE	A	B	C	D	WEIGHT (LBS)
2	2 3/8	4 1/8	2 3/8	1/8	5
2 1/2	2 5/8	4 7/8	2 5/16	3/8	-
3	2 7/8	5 3/8	3 3/4	9/16	10
4	2 7/8	6 7/8	4 1/2	7/8	14
5	3 1/4	7 11/16	5 11/16		-
6	3 7/8	8 3/4	6 5/8	1 1/4	29
8	5	11	8 5/8	2 1/16	53
10	5 3/4	13 3/8	10 3/4	2 3/4	91
12	7 1/8	16 1/8	12 5/8	2 9/16	151
14	7 1/4	17 3/4	13 11/16	3 3/4	176
16	7 1/2	20 1/4	16 11/16	4 1/8	-
18	8	21 5/8	18	4 3/8	292
20	8 5/8	23 7/8	20 1/4	5 15/16	417
24	8 3/4	28 1/4	23 3/4	7 1/2	556
26	11 1/4	30 1/2	24 3/4	8	-
28	12 5/8	32 3/4	27 5/8		-
30	12	34 13/16	30 1/8	9 1/8	-
32	14	37	30 11/16		-
36	14 1/2	41 1/4	34	9 11/16	-
40	17	45 3/4	38 13/16		-
42	17	48	41 13/16	11 1/2	-
48	20 5/8	54 1/2	47	14 1/4	-
54	21 1/4	60 7/8	50 1/2		-

PARTS LIST			
ITEM	DESCRIPTION	SPECIFICATIONS	QTY
1	SEAT/SEAL	VITON/316 STAINLESS STEEL	1
2	DISC	SA351 CF8M	2
3	SHAFT	316 STAINLESS STEEL	2
4	TORSION SPRING	INCONEL	2
5	CAST BODY	SA351 CF8M	1

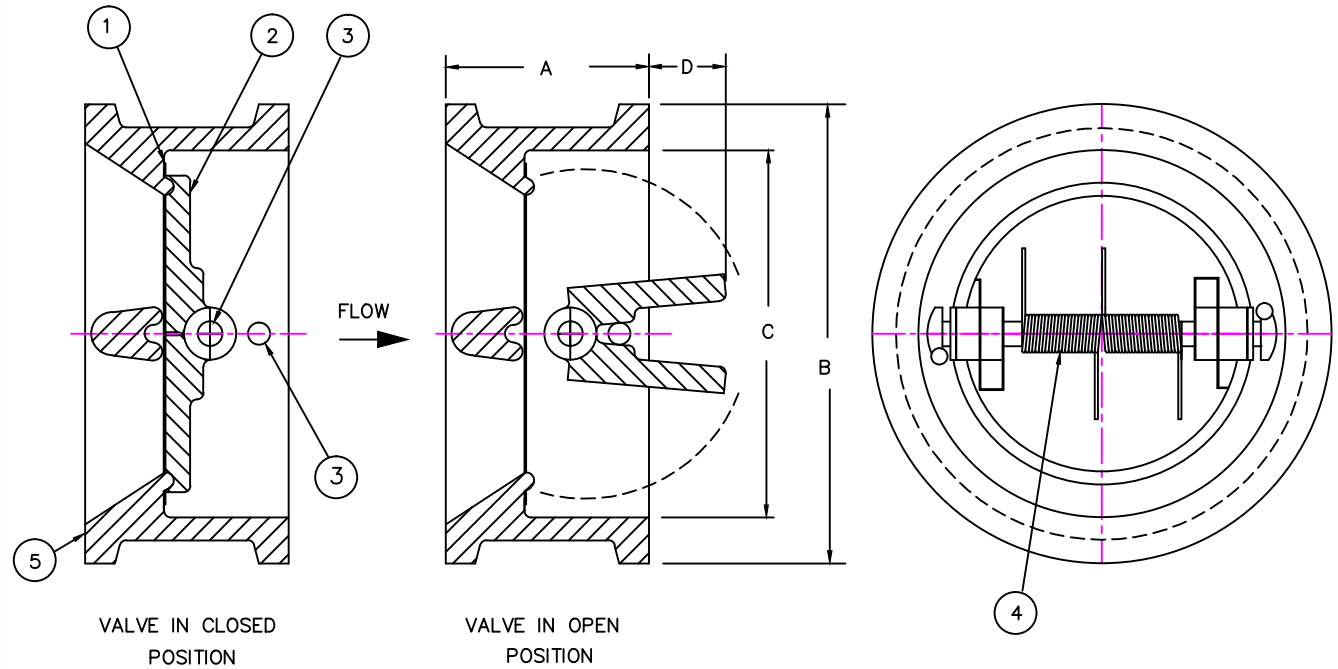

NOTE:
 FOR SIZES 10" AND UPWARDS VALVE IS TAPPED
 FOR EYEBOLT FOR LIFTING
 FOR APPROVAL OR QUOTATION PURPOSE ONLY

B	DIM. A OF 2.5" SIZE WAS 2 3/8"	09-09-16
A	CHANGED SIZE 6" TO 10" IN NOTES	11-23-07
REF	REVISIONS	DATE

SURE FLOW EQUIPMENT INC.
 This drawing is the property of Sure Flow Equipment Inc. It shall not be copied or duplicated in any manner and shall not be submitted to outside parties for examination without the written consent of Sure Flow Equipment Inc. It shall be used for reference to work under contract, or for proposals submitted by Sure Flow Equipment Inc. only.

Sure Flow Equipment Inc.
 BURLINGTON, ONTARIO, CANADA

Model 2"-54" FE150SS CHECK VALVES

Drawn C.MACORETTA	Approved	Scale NTS
Date JULY 4/07	Drawing Number Q04768	Rev. A